



Lochinvar[®]
High Efficiency Water Heaters, Boilers and Pool Heaters

EFFICIENCY+[®]
BOILER
Submittal Sheet

EBN-Sub-05

EFFICIENCY+[®] GAS BOILERS

JOB NAME _____

LOCATION _____

ARCH./ENGR. _____

WHOLESALE _____

MECH. CONTRACTOR _____

MODEL NO. _____

TYPE GAS _____

Btu/hr INPUT _____

Btu/hr OUTPUT _____

NOTES

Standard Features

- 84% AFUE
- Two Stage Firing
- Sealed Combustion Chamber
- Stainless Steel Burners
- Low NOx Operation Exceeds the most Stringent Air Quality Requirements
- ASME Copper Finned Tube Heat Exchanger
- 160 PSI Working Pressure
- Gasketless Heat Exchanger Design
- Automatic Reset High Limit
- Loch-Heat Ceramic Tile Combustion Chamber
- Hot Surface Ignition
- ASME Pressure Relief Valve
- 24 Volt Control System
- Pump Relay
- 10 Year Limited Warranty on Heat Exchanger (See warranty for details)

Optional Equipment

Place an X in the box by all options that apply

- Adjustable High Limit w/ Manual Reset
- Alarm Bell
- Cupro-Nickel Heat Exchanger
- Flow Switch
- Indoor/Outdoor Reset
- Manual Reset Low Water Cut-Off w/test
- MP² Sequencer
- Stack Frame
- Pump Delay w/ Freeze Protection

Firing Control Systems

- M9 Hot Surface Ignition with Electronic Supervision (Standard)
- M7 California Code

Efficiency+® Boiler Dimensions & Specifications

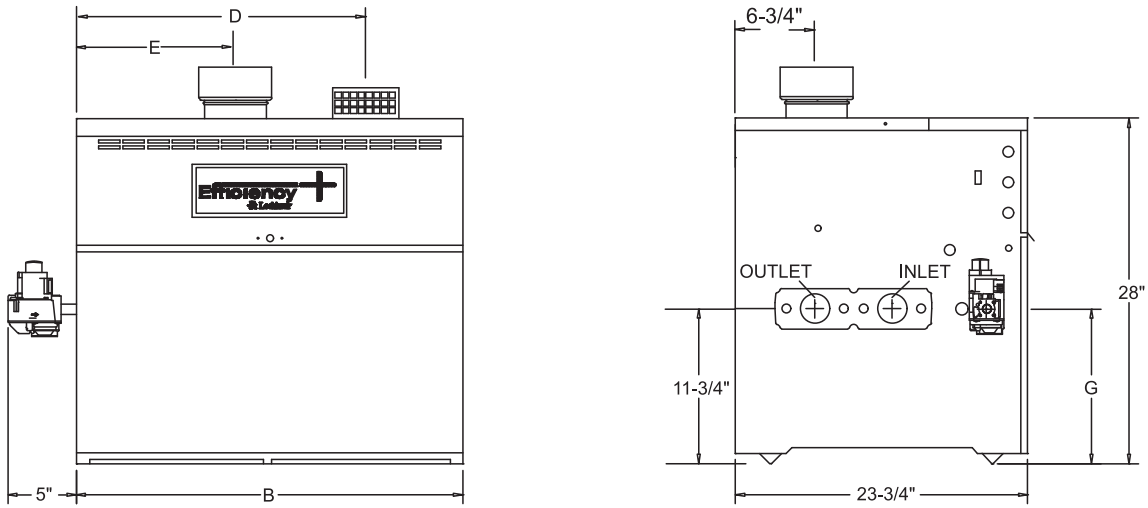

Efficiency+ Boiler					Dimensions & Specifications						
Model Number	Input Max MBH	AFUE %	Heating Capacity MBH	Net I=B=R MBH	B	D	E	G	Gas Conn.	Vent Size	Shipping Weight
EBN150	150	83.2	129	112	19-3/4"	16"	7-1/4"	11-3/4"	3/4"	5"	245
EBN200	200	83.1	170	148	23-3/4"	20"	9-1/4"	11-3/4"	3/4"	5"	265
EBN250	250	83.2	218	190	27-1/2"	23-3/4"	11"	11-3/4"	3/4"	6"	290
EBN300	300	84.0	252	219	31-1/4"	27-1/2"	13"	11-3/4"	3/4"	6"	310

Notes: Change 'N' to 'L' to denote L.P. gas models

Electrical Requirements: 120 VAC / 2 AMP Water connections are 1-1/2" NPT

Performance data based on manufacturer test results.

Venting Options

- Conventional
- Efficiency+ DirectAire
- Direct Vent Vertical
- Direct Vent Horizontal
- Outdoor

AMP DRAW DATA 150,000 thru 300,000 Btu Models					
FIRING CONTROLS	FAN	VALVE/ CONTROLS	MAXIMUM TOTAL AMPS @ 120 VAC	PUMP AMPS 100	PUMP AMPS 150-300
F-9 (Single Stage)	1.15	3.97	5.12	2.1	5.8
M-9 (Two Stage)	1.15	4.15	5.30	2.1	5.8

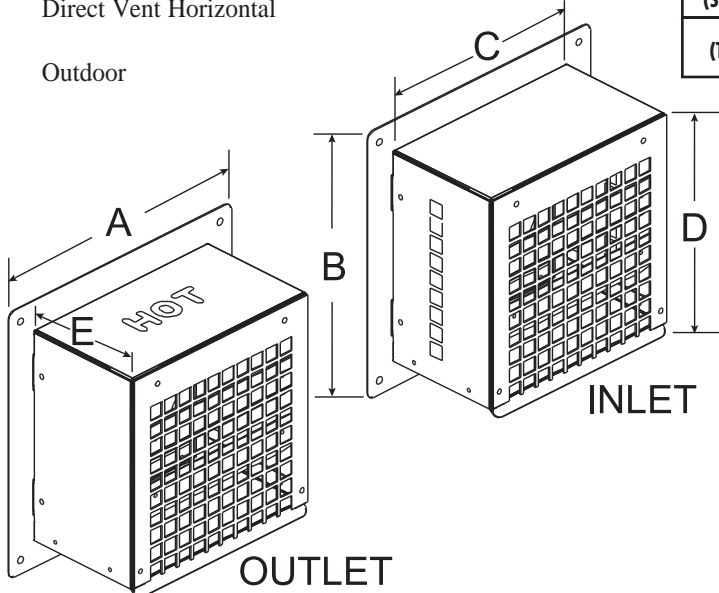

Horizontal Direct Vent Inlet and Outlet Cap					
MODEL NO.	DIM "A"	DIM "B"	DIM "C"	DIM "D"	DIM "E"
EB 150-200	9-1/8"	8-7/8"	7-1/8"	7-3/8"	4-3/8"
EB 250-300	9-5/8"	9-3/8"	7-5/8"	7-3/4"	4-3/8"



Lochinvar®
High Efficiency Water Heaters, Boilers and Pool Heaters



Lochinvar Corporation • 300 Maddox Simpson Pkwy • Lebanon, TN 37090 • 615-889-8900 / Fax: 615-547-1000
www.Lochinvar.com